

Fort Vermilion and Area Board of Trade

2017 Airport Terminal Presentation

2017 Fort Vermilion and Area Board members: All Volunteers, only Secretary Treasurer receives \$250/month honorarium

Chair = Lucille Labrecque, Vice Chair= Danny Friesen, Secretary and Treasurer= Sara Schmidt, Directors: Erick Carter, Martin Stanners, Charles LaForge, Brad Doerksen. We currently have 35 Members, an improvement from previous years.

We want to focus on community development opportunities that meet our mission and vision.

Mission: To create and promote business partnerships and opportunities in the community of Fort Vermilion

Vision: A Vibrant and energetic community that connects tourism, business and agriculture.

For 2018 we propose to acquire the old **airport terminal building** for a Board of Trade/Tourism office.

RATIONALE

Since highway 88 has been paved the traffic south of the town centre has increased significantly. Fort Vermilion businesses and community events are not being maximized because significant traffic drives on by the core of Fort Vermilion. We worked with Andrew O'Rourke to get traffic statistics for the proposed project area. See attached **traffic count** information.

We believe people will stop once an attractive, historical, informative venue that invites locals and visitors to the community. The museum has and will continue to offer services. We want to augment the Board of Trade services, tourism opportunities and museum displays.

Proposed Location Option A and Option B

Airport Terminal building

- **Moving and renovating building**

- BoT is aware of damage to the building that arose from the move to current site. For the purpose of an "office" type building it meets BOT's needs. Renovations will be required so the damage becomes part of the renovation.

Building is self- contained: potable water and option for septic tank

Building has windows, office space, meeting room space, rest rooms

BoT has board members and other volunteers that will help with this specific project. Examples: Brad Doerksen with Extreme Construction, Erick Carter with equipment and hours, Charles LaForge with lamp posts and top soil, Danny Friesen with hours and family networking and volunteers. Once people see the project begin they get involved. We as the BoT and Mackenzie County need to lead the project.

- Attraction / Display. **York Boat**, trailer and all the memorabilia from Geo Tourism 2011 adventure on the Peace. The package includes Hudson Bay jackets, pine chests, oars, mast, sail, ropes, flags. We want to feature these at and in the old terminal building.
- Other displays:
 - Denny May has Wop May memorabilia he has offered for a memorial display
 - Feature the Dog Sled Team that is part of the Wop May story
 - Space to promote the many themed displays that the museum has stored
 - Place to feature and sell local art

- Venue to promote local crafters and sell their crafts. Currently these are at the High Level Museum and Tourist info
- Offer tourist a dumping station. Currently only one dumping station in Fort Vermilion.
- Vandalism:
 - Proposed site is on the outskirts of town, less people walking around at night
 - Shutter blinds on building for security
 - Security cameras installed
 - York Boat displayed in separate fenced area
 - Possible wire link fencing
- BOT Partnerships to move this project forward:
 - Memberships with **Mackenzie Frontier Tourism Association**
 - Membership with **Streetscape**
 - Membership with **REDI**
 - Partnership with Mackenzie County. BoT met with Doug Munn and Liane Lambert Nov 2017 to initiate conversation about project
 - Plan to meet with MARA to discuss partnering for location
 - Plan to partner with La Crete Heritage/Ag Society, contact Susan Friesen
 - Partner with Fort Vermilion Museum

- **FUNDING**

Requesting funds and/or promissory note/s from Mackenzie County to move the building (aprox. \$50,000). The matching grants are available for project. However BoT needs specific dollar commitments from County so we can apply for matching funding amounts.

- BoT has \$5000 in the bank
- 2017 Fundraising events for specific projects were successful. War memorial \$1500, Light up Fort Vermilion Christmas Tree \$75.

Grant funding opportunities:

- In Feb 2018 will apply for **Heritage Awareness grant** for matching grant up to \$15,000
- In May 2018 will apply for **Community Initiative Project based grant**- matching up to \$75,000
- In March 2018 will apply for **CFEP small grant- matching grant**

The Fort Vermilion and Area Board of Trade thanks you for your time and attention.

Sincerely,

Lucille Labrecque

Fort Vermilion Proposed Tourist Office



Lot Location

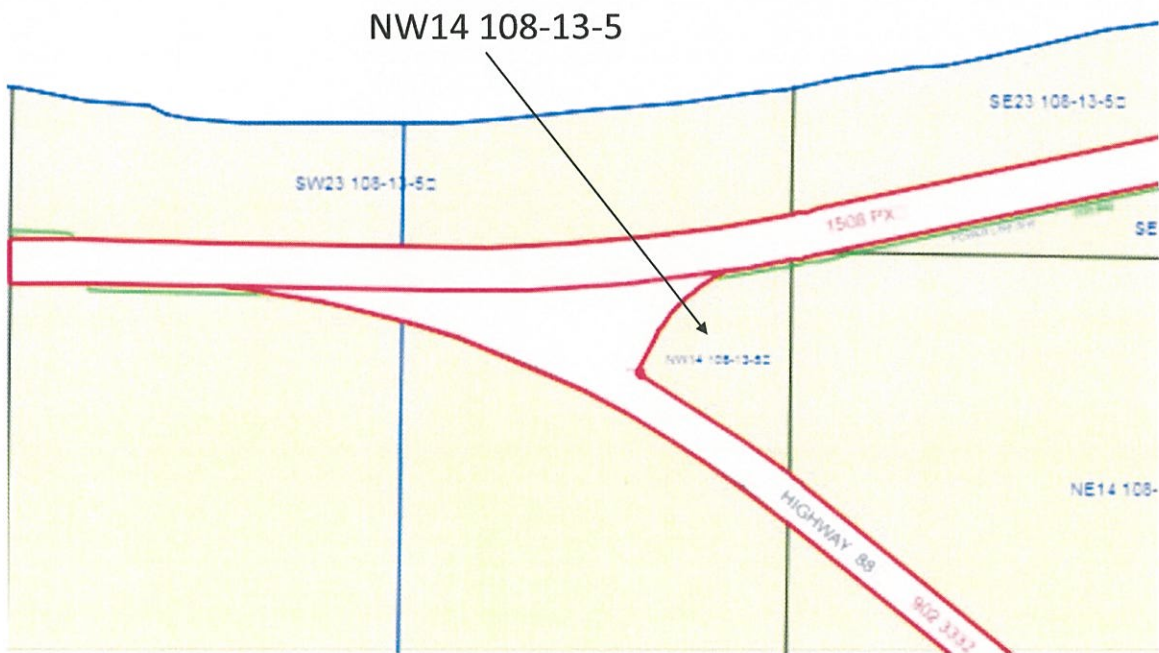

Lot Dimensions

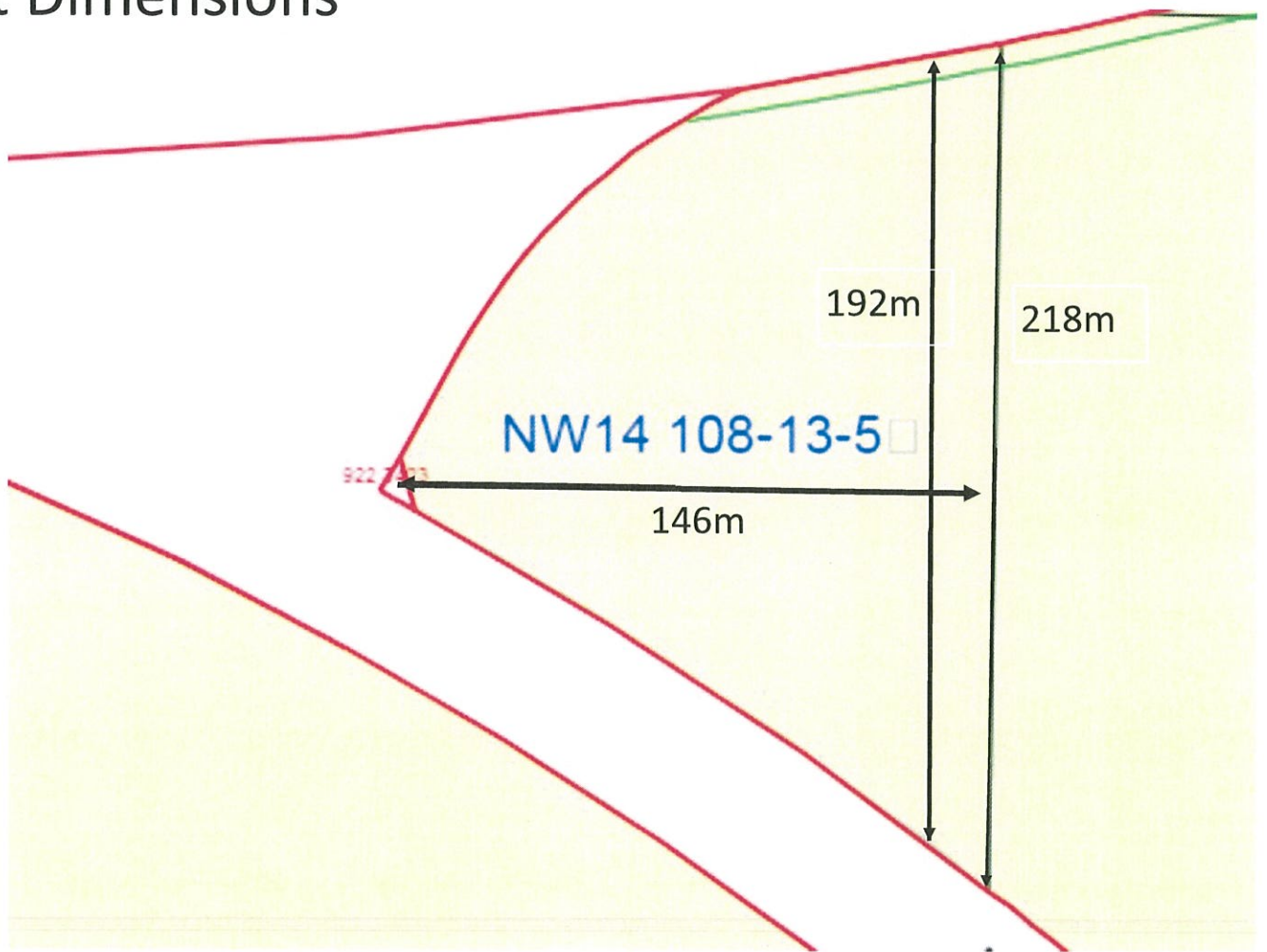

Site Plan

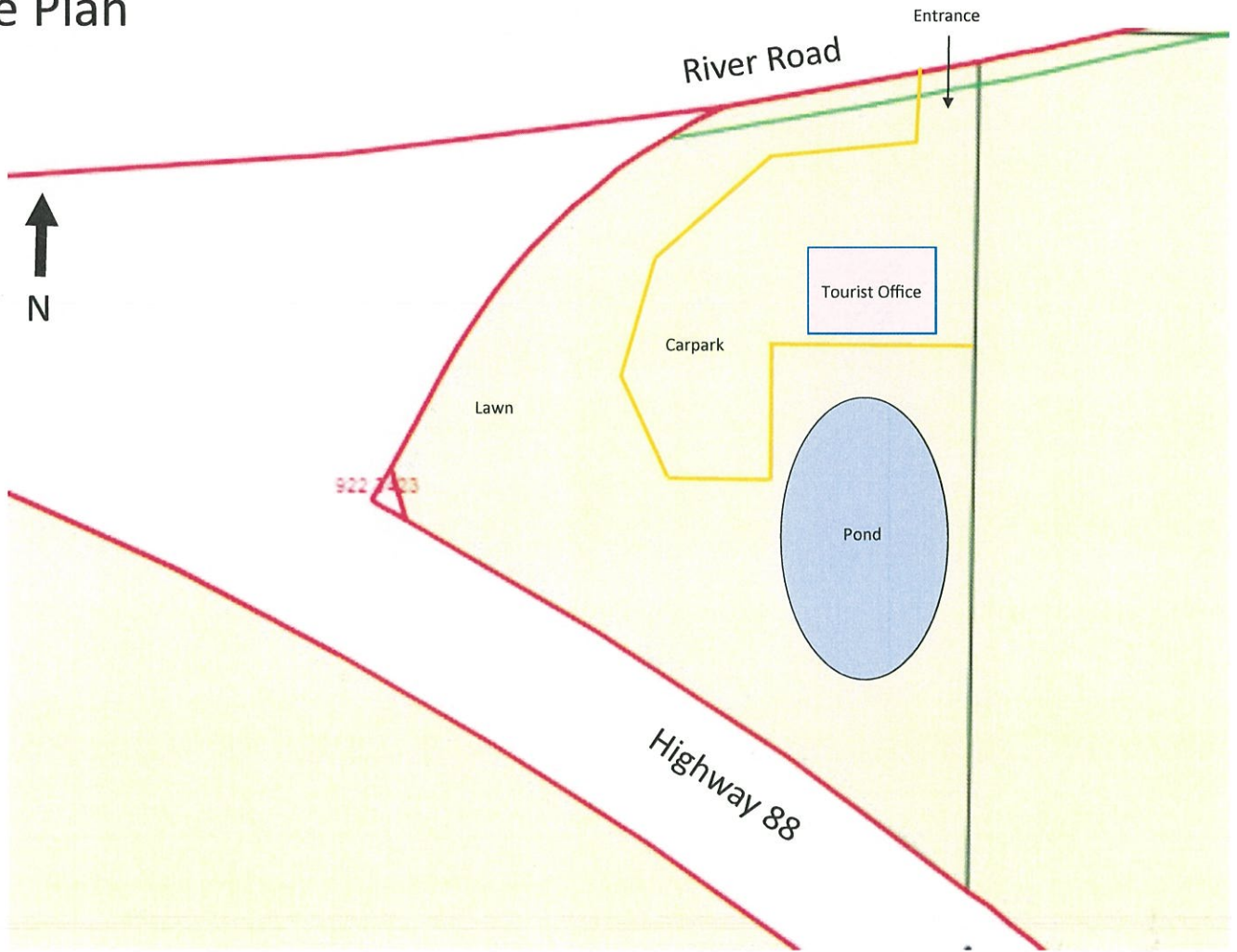

Traffic Counts 2016

Intersection of:

AADT = Annual Average Daily Traffic

88 & RIVER RD W OF FORT VERMILION 14-108-13-510500100



West On 88		
Vehicle Type	Vol	%
A: Passenger Vehicle	1205	88.6
B: Recreational Vehicle	15	1.1
C: Bus	6	0.4
D: Single Unit Truck	76	5.6
E: Tractor Trailer Unit	58	4.3
ASDT	1470	AADT 1360

North On River Rd		
Vehicle Type	Vol	%
A: Passenger Vehicle	654	96.2
B: Recreational Vehicle	9	1.3
C: Bus	2	0.3
D: Single Unit Truck	11	1.6
E: Tractor Trailer Unit	4	0.6
ASDT	740	AADT 680

East On 88		
Vehicle Type	Vol	%
A: Passenger Vehicle	591	82.1
B: Recreational Vehicle	6	0.8
C: Bus	4	0.6
D: Single Unit Truck	65	9.0
E: Tractor Trailer Unit	54	7.5
ASDT	780	AADT 720





10/10/2023 10:10:10 AM



Section 9 | Land Use District Regulations

9.9 Institutional (I)

Purpose

- 9.9.1 The purpose of the Institutional (I) district is to allow for a variety of public and private uses that provide medical, public safety, religious and cultural services/amenities to the community.



Permitted and Discretionary Land Use Classes

- 9.9.2 Land use classes within the following table shall be permitted or discretionary within the Institutional (I) district of this BYLAW.

Permitted	Discretionary
ACCESSORY BUILDING	CEMETERY
ASSISTED LIVING FACILITY	EXHIBITION GROUNDS
DAY CARE FACILITY	TEMPORARY/PORTABLE UNIT
EDUCATION FACILITY	WASTE MANAGEMENT
EXHIBITION FACILITY	
FIRE HALL OR FACILITY	
GOVERNMENT SERVICE	
HOSPITAL	
MUSEUM	
PARK	
PLACE OF WORSHIP	
RECREATION SERVICE, INDOOR	
RECREATION SERVICE, OUTDOOR	
TOURIST INFORMATION FACILITY	

Section 9 | Land Use District Regulations

Regulations

- 9.9.3 In addition to the regulations contained in Section 8, the following standards shall apply to every DEVELOPMENT in this LAND USE DISTRICT.

Regulation	Standard
Lot Dimensions	At the discretion of the Development Authority
Min. Setback	
Yard – Front	7.6m (25.0ft)
Yard – Exterior Side	3.0m (10.0ft)
Yard – Interior Side	1.5m (5.0ft)
Yard – Rear	3.0m (10.0ft) 1.5m (5.0ft) for underground utilities 2.4m (8.0ft) for overhead utilities

Additional Regulations

- 9.9.4 A PLACE OF WORSHIP, EDUCATION FACILITY, PARK, DAY CARE FACILITY or other similar use shall not be located within 152.4m (500.0ft) of a Direct Control District.
- 9.9.5 In addition to Section 8.32 of this BYLAW, the Development Authority may require any DISCRETIONARY USE to be screened from view with a vegetated buffer strip and/or other SCREENING of a visually pleasing nature, satisfactory to the Development Authority.
- 9.9.6 The architecture, construction materials and appearance of buildings and other structures shall be to accepted standards and shall complement the natural features and character of the site to the satisfaction of the Development Authority.
- 9.9.7 In addition Section 8.60 of this BYLAW relates specifically to development south of Township Road 1062 (88 Connector Road).
- 9.9.8 The Development Authority may decide on such other requirements as are necessary having due regard to the nature of the proposed DEVELOPMENT and the purpose of this DISTRICT.

Reference No.: 70000099

Intersection of:

88 & RIVER RD W OF FORT VERMILION 14-108-13-510500100

2016 AADT / ASDT ESTIMATES

North On River Rd		Vol	%
Vehicle Type			
A: Passenger Vehicle		654	96.2
B: Recreational Vehicle		9	1.3
C: Bus		2	0.3
D: Single Unit Truck		11	1.6
E: Tractor Trailer Unit		4	0.6
ASDT	740	AADT	680

West On 88			
Vehicle Type			
A: Passenger Vehicle	1205	88.6	
B: Recreational Vehicle	15	1.1	
C: Bus	6	0.4	
D: Single Unit Truck	76	5.6	
E: Tractor Trailer Unit	58	4.3	
ASDT	1470	AADT	1360

East On 88			
Vehicle Type			
A: Passenger Vehicle	591	82.1	
B: Recreational Vehicle	6	0.8	
C: Bus	4	0.6	
D: Single Unit Truck	65	9.0	
E: Tractor Trailer Unit	54	7.5	
ASDT	780	AADT	720

TURNING MOVEMENT ABBREVIATIONS

- NR: Traffic From North Turning Right
- NL: Traffic From North Turning Left
- NT: Traffic From North Proceeding Through
- SR: Traffic From South Turning Right
- SL: Traffic From South Turning Left
- ST: Traffic From South Proceeding Through
- ER: Traffic From East Turning Right
- EL: Traffic From East Turning Left
- ET: Traffic From East Proceeding Through
- WR: Traffic From West Turning Right
- WL: Traffic From West Turning Left
- WT: Traffic From West Proceeding Through

TURNING MOVEMENT ABBREVIATIONS

- AADT: Average Annual Daily Traffic
Average daily traffic expressed as vehicles per day for period of January 1 to December 31 (365 days)
- ASDT: Average Summer Daily Traffic
Average daily traffic expressed as vehicles per day for period of May 1 to September 30 (153 days)

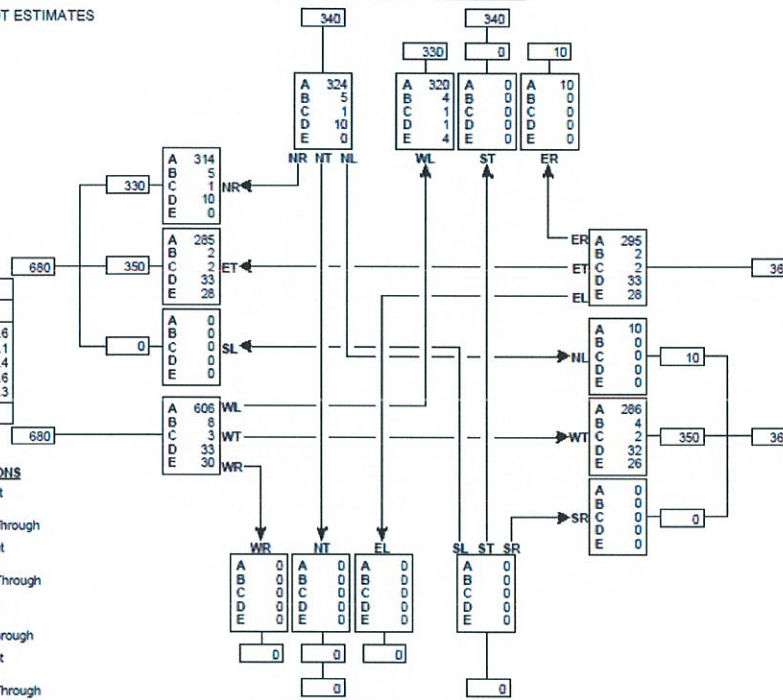

South On		Vol	%
Vehicle Type			
A: Passenger Vehicle		0	0.0
B: Recreational Vehicle		0	0.0
C: Bus		0	0.0
D: Single Unit Truck		0	0.0
E: Tractor Trailer Unit		0	0.0
ASDT		AADT	0

Reference No.: 70000099

Intersection of:

88 & RIVER RD W OF FORT VERMILION 14-108-13-510500100

2016 a.m. 100th Highest Hour ESTIMATES

Turning Movement Summary Diagram

North On River Rd		
Vehicle Type	Vol	%
A: Passenger Vehicle	58	87.9
B: Recreational Vehicle	2	3.0
C: Bus	1	1.5
D: Single Unit Truck	5	7.6
E: Tractor Trailer Unit	0	0.0
Total	66	

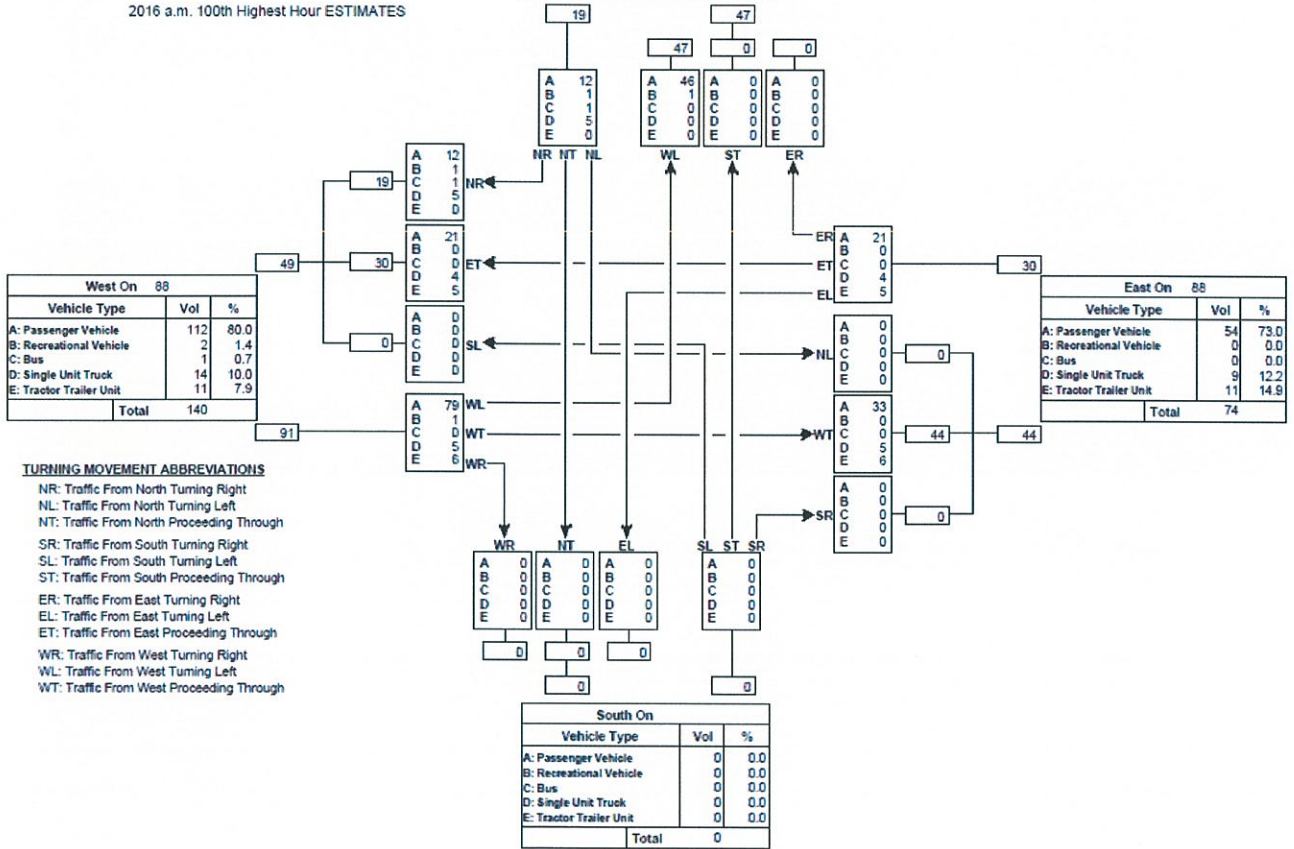

Reference No.: 70000099

Intersection of:

88 & RIVER RD W OF FORT VERMILION 14-108-13-510500100

2016 p.m. 100th Highest Hour ESTIMATES

Turning Movement Summary Diagram

North On River Rd		
Vehicle Type	Vol	%
A: Passenger Vehicle	68	98.6
B: Recreational Vehicle	0	0.0
C: Bus	0	0.0
D: Single Unit Truck	1	1.4
E: Tractor Trailer Unit	0	0.0
Total	69	

West On 88		
Vehicle Type	Vol	%
A: Passenger Vehicle	133	94.3
B: Recreational Vehicle	1	0.7
C: Bus	0	0.0
D: Single Unit Truck	5	3.5
E: Tractor Trailer Unit	2	1.4
Total	141	

East On 88		
Vehicle Type	Vol	%
A: Passenger Vehicle	67	90.5
B: Recreational Vehicle	1	1.4
C: Bus	0	0.0
D: Single Unit Truck	4	5.4
E: Tractor Trailer Unit	2	2.7
Total	74	

South On		
Vehicle Type	Vol	%
A: Passenger Vehicle	0	0.0
B: Recreational Vehicle	0	0.0
C: Bus	0	0.0
D: Single Unit Truck	0	0.0
E: Tractor Trailer Unit	0	0.0
Total	0	

- TURNING MOVEMENT ABBREVIATIONS**
- NR: Traffic From North Turning Right
 - NL: Traffic From North Turning Left
 - NT: Traffic From North Proceeding Through
 - SR: Traffic From South Turning Right
 - SL: Traffic From South Turning Left
 - ST: Traffic From South Proceeding Through
 - ER: Traffic From East Turning Right
 - EL: Traffic From East Turning Left
 - ET: Traffic From East Proceeding Through
 - WR: Traffic From West Turning Right
 - WL: Traffic From West Turning Left
 - WT: Traffic From West Proceeding Through

